

Optimal Operation and Control of a Thermal Energy Storage System: Classical Advanced Control versus Model Predictive Control

Cristina Zotica^a, David Pérez-Piñeiro^a, Sigurd Skogestad^{a*}

*^aDepartment of Chemical Engineering, Norwegian University of Science and Technology, Trondheim, NO-7491, Norway
Sigurd.Skogestad@ntnu.no*

Abstract

The objective of this work is to define the optimal operation and control for a thermal storage system with heat sources and a consumer, which exchange utilities using one hot water thermal energy storage tank. In this work, we compare a decentralized control structure using classical advanced control with PID controllers and logic blocks (split-range control and selectors) and a centralized control structure (model predictive control) to implement optimal operation for a simple thermal energy storage system, which is a multivariable system with constraints. We analyze a varying heat supply profile over a horizon of 24 hours. We show that the supply and demand can be balanced, and we achieve optimal operation by using the energy stored in the tank while minimizing the heat from the market.

Keywords: thermal storage, optimal operation, split range control, model predictive control

1. Introduction

Thermal energy storage has the potential to save energy in many applications by balancing the asynchronous supply and demand of heating and cooling. Furthermore, it can enhance the use of uncertain and highly fluctuating heat sources (e.g., power generation from solar thermal plants and/or re-utilization of industrial waste heat).

A large emphasis in the literature on energy storage has been placed on technology advances, design and applications (Arteconi et al., 2012; International Energy Agency, 2014). From an operational and control perspective, model predictive control has become the multivariable control technique of choice in several papers for controlling thermal energy storage systems in buildings, combined heat and power plants, and solar thermal power plants (Ma et al., 2009; Cole et al., 2012; Knudsen et al., 2019). Although less extensively, classical advanced control structures have also been studied in the context of thermal energy storage in buildings (de Oliveira et al., 2016). In this work, we show how to use classical advanced control using PID controllers and logic blocks (split-range control and selectors) to control a simple thermal energy storage system, which is a multivariable system with constraints. The control performance of the proposed solution is compared with model predictive control (MPC).

This paper is organized as follows. In Section 2, we describe a typical thermal storage system, in Section 3 we describe both a decentralized and a centralized control structure

for the system, in Section 4, we present a simulation case study, and we make our final remarks in Section 5.

2. Thermal storage system

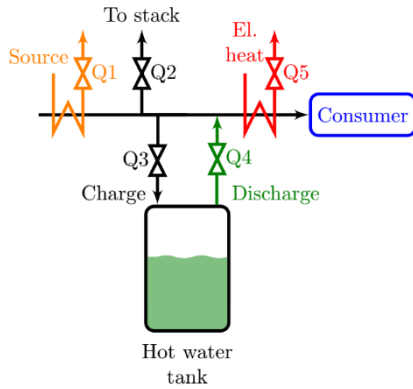

Figure 1. Process flowsheet indicating the five degrees of freedom for operation.

The process studied in this work is a thermal storage system illustrated in Figure 1. For example, this can be a district heating network, or an industrial cluster formed of heat sources and heat sinks. We consider a general system, composed of a variable heat source (Q_0) that utilizes industrial waste heat, an electric boiler that employs electricity from the market (Q_5), one consumer plants with heat demand (Q), and a hot water tank used for energy storage. The tank can either be charged (Q_3) or discharged (Q_4). The tank acts as a buffer between a varying heat supply and demand to minimize electric heating. Note that we may also heat the tank directly with electric heating (not shown in the figure). Excess heat is sent to the stack (Q_2).

Considering the relationship between demand and supply we can identify three cases:

- Case 1. Low demand. No storage tank \Rightarrow send excess heat to the stack (Q_2).
- Case 2. Intermediate demand. Use tank to balance heat demand and supply.
- Case 3. High demand. No storage tank \Rightarrow buy electric heating (Q_5).

We analyse case 2, and we consider a scenario with constant electricity prices. Note that with constant electricity prices we would not gain from charging the tank with electric heating and discharge it subsequently to the consumer. We should instead supply the consumer directly with electric heat to minimize heat losses.

2.1. Process model

We discuss optimal operation on a simple thermal storage example, and we start by deriving a model based on first principle. On the consumer side, we assume that the dynamics are considerable faster compared to the slow tank dynamics, and we write the steady-state energy balance, given by Eq. (1).

$$Q = Q_1 + Q_4 + Q_5 \quad (1)$$

We assume constant density (ρ), heat capacity (c_p), and volume (V). The energy balance in temperature (T) form for the tank is given by Eq. (2).

$$\frac{dT}{dt} = \frac{1}{\rho c_p V} (Q_3 - Q_4) \quad (2)$$

where, Q_3 is the excess heat, given by a static energy balance in Eq. (3).

$$Q_3 = \max(0, (Q_0 - Q_1 - Q_2)) \quad (3)$$

3. Optimal operation and control

We analyse the system in the setting of plantwide control (Skogestad 2004), and we systematically define the operational objective, manipulated variables (MVs) (i.e. degrees of freedom for optimal operation), operational constraints, main disturbances and controlled variables (CVs). The operational objective of the system is to keep the heat demand setpoint, while minimizing electric heating. Table 1 shows the MVs (also shown in Figure 1. Process flowsheet indicating the five degrees of freedom for operation., CVs, and main disturbances.

Table 1 Manipulated variables, controlled variables and disturbances

Manipulated variables	Controlled variables	Disturbances
MV1: Heat directly to consumer (Q1)	CV1: Consumer heat demand	D1: Heat supply
MV2: Heat to stack (Q2)	CV2: Tank temperature	D2: Electricity prices (not considered in this work)
MV3: Heat to tank (Q3) (not independent)		
MV4: Heat from tank (Q4)		
MV5: Electric heating (Q5)		

Furthermore, during operation the tank water temperature must satisfy the following constraints, as given by Eq. (4).

$$T^{\min} < T < T^{\max} \quad (4)$$

where T^{\min} is given by the consumer process specifications and T^{\max} is the allowed maximum temperature in the tank given by operation constraints.

With the constant electricity prices assumption, optimal operation is trivial, and three regions can be defined:

- R 1. $Q < Q_0$. Charge the tank with surplus heat until $T = T^{\max}$.
- R 2. $Q > Q_0$. Discharge the tank.
- R 3. $Q > Q_0$ and $Q_3 = 0$ (fully discharged tank). Buy electric heat from the market.

The operational challenge arises from the fact that the degrees of freedom are dynamic, that is, they are not available at all time (i.e. once the tank is discharged it can no longer supply the consumers). The question we want to answer is: what is the simplest way to implement optimal operation? We compare a decentralized control structure using

classical advanced control using PID-controllers and logic, and centralized control structure using Model Predictive Control (MPC).

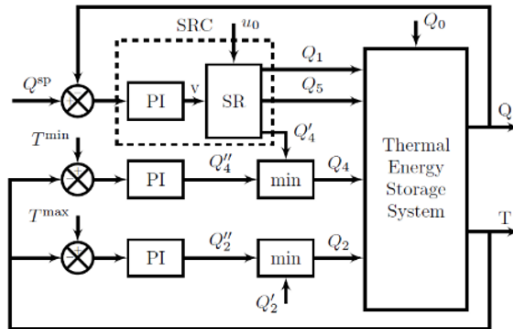

Figure 2 Decentralized control structure with split range control and min selectors. The split range (SR) block is represented in Figure 3

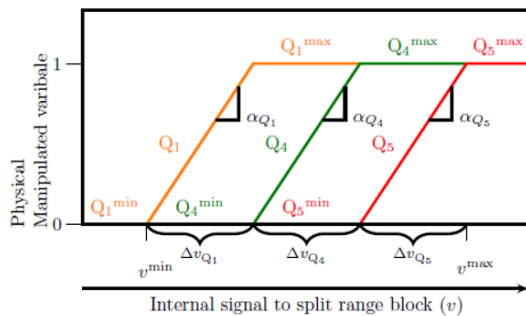

Figure 3 . Split range block

and the active set constraints changes, we use a min selector to give-up discharging the tank. Similarly, when $T \geq T^{\max}$, we use a min selector to give-up charging the tank.

Figure 3 shows the split range block. Note that this is not a typical split range controller because of the dynamic degrees of freedom. Consider a case when the tank is fully discharged ($Q_3=0$), there is no heat supply ($Q_0=0$), and we operate on the red line in the split range block in Figure 3. If the heat demand decreases, we could in theory operate on the green line using Q_3 , but this is not physically possible because the tank is discharged. To solve this issue, we propose to update the maximum values (Q_1^{\max} and Q_3^{\max}) in the split range block to reflect the operational constraints. We set $Q_3^{\max}=0$, when the tank is discharged (i.e. $T=T^{\min}$), and $Q_1^{\max} = Q_0$. We follow the systematic design procedure from the work of (Reyes-Lua 2019) to design the split range controller. In the split range block, the split value is set at $v^*=0$, which corresponds to maximum Q_1 , and minimum Q_3 and Q_4 . The slopes \pm in the split block are equal, because the process gains from MVs to CV are equal. To tune the PI-controllers, we use the SIMC tuning rules (Skogestad2003). Note that Eq. 3 is static, and we need to use a pure I-controller. The tuning parameters for

3.1. Decentralized control with classical advanced control structures

Optimal operation can be implemented in practice using classical advanced control structure, i.e. cascade, feedforward, valve position control or split range control together with logic elements (selectors) (Reyes-Lua and Skogestad, 2019). Split range control is a multiple-inputs single-output control structure that allows to use one input at a time and extends the steady-state operating range for the controlled variable. In this work we propose a control structure with split range control (SRC) and selectors, which can be used for active constraints changes (Reyes-Lua et al., 2018). Figure 2 shows the block diagram of the proposed decentralized control structure. The SRC keeps the heat demand setpoint Q^{SP} by manipulated the heat flows Q_1 , Q_4 , and Q_5 . However, when $T \leq T^{\min}$,

the split range controller are: slope $\pm=3$, and integral gain $K_I=0.033$. The other PI-controllers are tuned following the SIMC rules for integrating processes.

3.2. Centralized control. Model predictive control

Model predictive control solves an open loop control problem subject to constraints with a finite horizon at each sampling time to determine an optimal control sequence, and the first control is applied to the plant (Mayne et al., 2000). It's main advantage it that it handles constraints and interactive processes by design, while it's disadvantage is that it required a details model.

We formulate the optimal control problem as to minimize electric heating (Q_5), heat discharged (Q_3) and heat sent to stack (Q_2) subject to model equations and operational constraints, as given in Eq. (5).

$$\begin{aligned}
 & \min \sum_{k=1}^N \omega_2 Q_{2k}^2 - \omega_4 Q_{4k}^2 + \omega_5 Q_{5k}^2 & (5) \\
 & s.t. Q_k - Q_k^{sp} = 0 \\
 & Q_k = f(Q_{i_k}), \forall i \in \{1, 4, 5\} \\
 & T_k = g(Q_{i_k}), \forall i \in \{3, 4\} \\
 & 0 < Q_{i_k} < Q_{i_k}^{\max}, \forall i \in \{1, 3, 4, 5\} \\
 & T_k^{\min} < T_k < T_k^{\max} \\
 & \forall k \in \{1, \dots, N\}
 \end{aligned}$$

where, ω_j are the weights in the optimization problem and $Q_1^{\max} = Q^0$.

4. Simulation results

We analyze a varying heat supply profile over a horizon of 24 hours with a constant heat supply, as shown in Figure The tank volume is $V = 100$, the initial tank temperature is $T_0=105$ °C. The MPC is solved in CasADi (Andersson et al., 2013), and IPOT is used to solve the NLP (Wächter and Biegler, 2005). We use $N = 60$ control intervals and a sampling time of 60 s and $\omega_2 = 10, \omega_4 = 10^3, \omega_j = 10^4$

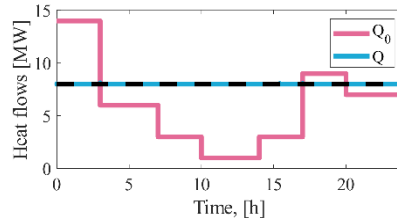

Figure 4. Variable heat supply in pink, and constant heat demand in blue

Figure 4, Figure 5, and 6 show the simulations results. Full lines show SRC and the dotted lines MPC.

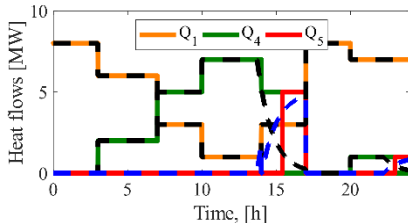

Figure 5. Input usage for SRC and MPC

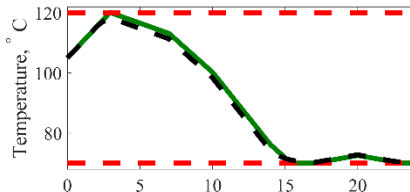

Figure 6. Temperature profile for SRC and MPC

5. Discussion and conclusions

In this work we identify optimal operation for a simple thermal energy storage system with constant electricity prices. We compare a decentralized control structure using PID controllers and logic blocks (split-range control and selectors) and a centralized control structure using MPC to implement optimal operation. For this example, we have shown that a systematically designed advanced control structure using SRC and selectors gives similar performance compared to MPC. The simulation results from Figures 4, 5 and 6 shows that the tank is discharging heat when the heat supply is not enough, and electric heat is used when the tank is fully discharged, while satisfying the operational constraints. Comparing both alternatives, SRC is considerable easier to implement in practice and tune and does not require as full detail model as MPC. However, for a larger scale process, PID-controllers and logic might not provide a simple implementation.

Acknowledgment - This publication has been partly funded by HighEFF - Centre for an Energy Efficient and Competitive Industry for the Future, an 8-years' Research Centre under the FME-scheme (Centre for Environment-friendly Energy Research, 257632). The authors gratefully acknowledge the financial support from the Research Council of Norway and user partners of HighEFF.

References

- J. Andersson, 2013. A General Purpose Software Framework for Dynamic Optimization. Phd thesis, KU Leuven.
- A. Arteconi, N. J. Hewitt, F. Polonara, 2012. State of the art of thermal storage for demand-side management. *Applied Energy* 93, 371–389.
- W. J. Cole, K. M. Powell, T. F. Edgar, 2012. Optimization and advanced control of thermal energy storage systems, *Reviews in Chemical Engineering*. 28. 10.1515/revce-2011-0018.
- International Energy Agency, 2014. Technology Roadmap. Energy storage. Tech. rep., International EnergyAgency.
- B. R. Knudsen, H. Kauko, T. Andresen, 2019. An Optimal-Control Scheme for Coordinated Surplus-Heat Exchange in Industry Clusters. *Energies*.
- Y. Ma, F. Borrelli, B. Hancey, A. Packard, S. Bortoff, 2009. Model predictive control of thermal energy storage in building cooling systems. In: *Proceedings of the 48th IEEE Conference on Decision and Control (CDC) held jointly with 2009 28th Chinese Control Conference*. IEEE, pp. 392–397.
- D.Q. Mayne, J.B. Rawlings, C.V.Rao, and P. O. M. Scokaert (2000). Constrained model predictive control: Stability and optimality. *Automatica*, 36(6):789–814.
- A. Reyes-Lua, C. Zotica, S. Skogestad, 2018. Optimal Operation with Changing Active Constraint Regions using Classical Advanced Control. *IFAC-PapersOnLine* 51 (18), 440–445.
- A. Reyes-Lúa, A. and Skogestad, S., 2019. Systematic Design of Active Constraint Switching Using Classical Advanced Control Structures. *Industrial & Engineering Chemistry Research* (In Press)
- A. Reyes-Lúa, C. Zotica, S. Skogestad, 2019. Systematic Design of Split Range. *IFAC-PapersOnLine* 53 (1), 898–903.
- S. Skogestad, 2003. Simple analytic rules for model reduction and PID controller tuning. *Journal of Process Control* 13 (4), 291–309.
- S. Skogestad, 2004. Control structure design for complete chemical plants, *Computers and Chemical Engineering* 28 (1-2) 219-234.
- A. Wächter, L. T. Biegler, Apr. 2005. On the implementation of an interior-point filter line-search algorithm for large scale nonlinear programming. *Mathematical Programming* 106 (1), 25–57.